

**SPECIFICATIONS
FOR
HIGH STRENGTH STRIPPER
HTS-11**

1. General

These specifications cover high strength stripper HTS-11. The HTS-11 is designed to strip primary coating of the optical fiber for high tensile strength splicing. The primary coating is first softened by heat, and stripped with a pair of blades. The blades do not touch the surface of the bare fiber part and the fiber tensile strength is kept as it basically is.

HTS is specially designed to accommodate fiber holder for FSM-30PF, fusion splicer for high tensile strength splicing / short cleaved length splicing.

2. Components and accessories

List of standard components

NO.	ITEM	MODEL	Q'TY
1	High strength stripper	HTS-11	1 pc
2	Stripping blades for 250um	HTS-11-CT (250)	1 pc
3	AC Adapter	ADC-08	1 pc
4	AC cord	ACC-08/09/10/11/12	1 pc
5	Cleaning brush	BRS-1	1 pc
6	Instruction manual (English)	-	1 pc

List of optional accessories

NO.	ITEM	MODEL	Q'TY
1	Stripping blades for 250um	HTS-11-CT (250)	1 pc
2	Stripping blades for 400um	HTS-11-CT (400)	1 pc
3	Fiber holder for 250um	FH-30PF-250H	1 pair
4	Fiber holder for 400um	FH-30PF-400H	1 pair
5	Grease (Heat sinker)	HTS-11-GREASE	1 pc
6	Slide block for 14mm cleaved length	HTS-11-BL (05)	1 pc

3. Specifications

3.1 Applicable fiber	Cladding dia.	: 125 μ m
	Coating dia.	: 250 / 400 μ m (optional)
	Coating material	: UV cured resin
3.2 Applicable No. of fiber		: 1
3.3 Fiber coating length *1		: 15 mm (standard) : 5 mm with HTS-11-BL (05)
3.4 Stripping length		: Max. 35 mm
3.5 Heating temperature settings		: 120, 140, 160 or 180 °C (adjustable)
3.6 Heating time		: Approx. 3 sec.
3.7 Power supply		: 100 to 240 V a.c. (50 to 60 +/- 3Hz).
3.8 Dimensions		: 140(W) x 60(D) x 60(H) mm
3.9 Weight		: 600 g
3.10 Operating condition		: 0 to 40 °C, 10% to 85%RH (Non condensing)

*1 Fiber coating length

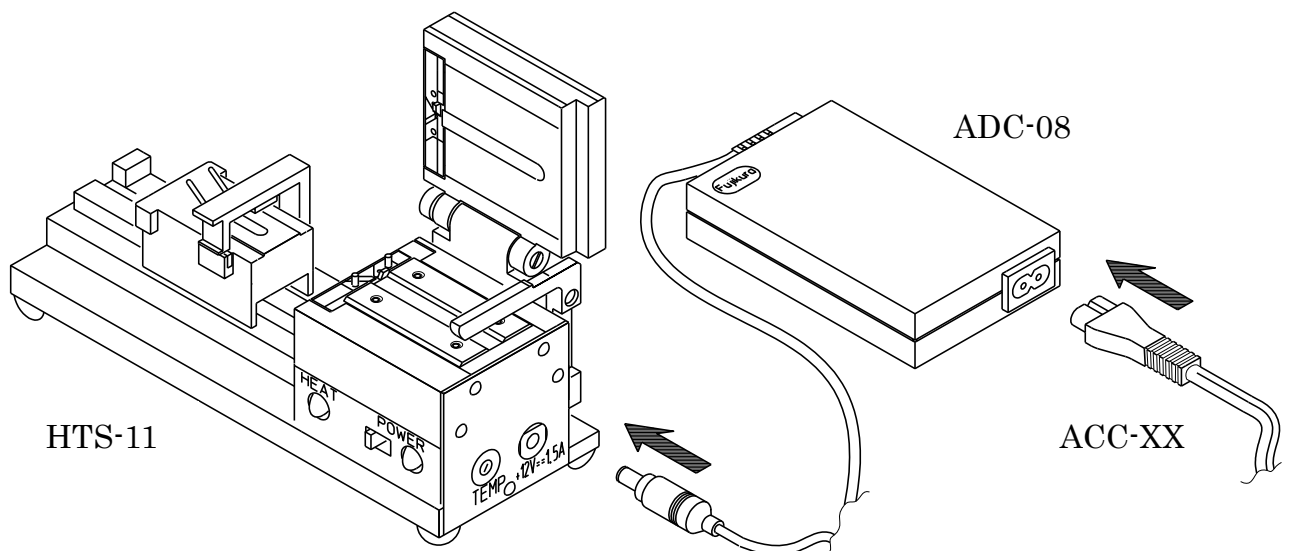
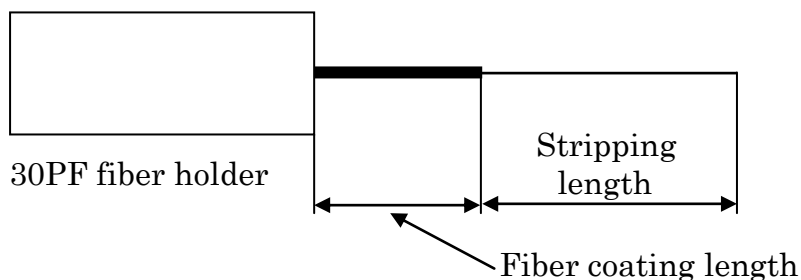

++ END OF SPECIFICATION ++